

LINEAR HALL EFFECT TOGGLE

HTL
HALL EFFECT
TOGGLE

2 & 4-WAY LINEAR HALL EFFECT TOGGLE



HTL4 with Castle Style Button

The HTL series provides all of the performance of a full size, dual axis joystick in a miniature package that can be mounted in control handles, armrests and panels. The Hall Effect sensors are protected against electromagnetic and radio frequency interference up to 100V/M. Programmable sensors with built-in temperature compensation ensure consistent and repeatable operation. The HTL series has excellent tactile feel for improved operator control and is available with either dusttight or IP68S watertight seal. A wide variety of output configurations are available to satisfy different applications.

Features:

- Designed for grip, armrest & panel mounting
- Proven contactless analog output Hall Effect technology
- Redundant outputs available
- 1 million cycles
- Electronics watertight to IP68S
- Outstanding EMI/RFI immunity
- Variety of button styles
- RoHS & WEEE compliant

Standard Characteristics/Ratings:

MECHANICAL:

Mechanical Life: 1,000,000 all directions

Travel Angle: 23° min to 27° max

Operating Force with Boot: 16 oz typical to 20 oz max (at top of button) @ 25°C

Max Allowable Vertical & Radial Force on Button: 25.0 lbs.

Max Allowable Torque on Button: 7.5 lbs.

ELECTRICAL RATINGS:

HTL2: Rated at Vcc = 5V @ 20°C Load = 1mA (4-7KΩ)

Electrical	Units	Min	Typ	Max
Supply Voltage	VDC	4.5	5	5.5
Output Voltage Tolerance at Center <i>(see graph for output values)</i>	VDC @ 5V Vcc	-0.25	N/A	+0.25
Output Voltage Tolerance at Full Travel <i>(see graph for output values)</i>	VDC @ 5V Vcc	-0.25	N/A	+0.25
Supply Current per Sensor	mA	N/A	8	10
Output Source Current	mA	-1	N/A	1
Output Resistance (I _o ≤ 2mA)	Ω	N/A	1	10

HTL4: Rated at Vcc = 5V @ 20°C Load = 1mA (4-7KΩ)

Electrical	Units	Min	Typ	Max
Supply Voltage	VDC	4.5	5	5.5
Output Voltage Tolerance at Center <i>(see graph for output values)</i>	VDC @ 5V Vcc	-0.25	N/A	+0.25
Output Voltage Tolerance at Full Travel <i>(see graph for output values)</i>	VDC @ 5V Vcc	-0.25	N/A	+0.25
Supply Current per Sensor	mA	N/A	8	10
Output Source Current Limit	mA	-1	N/A	+1

ELECTRONICS:

Seal Integrity: Electronics IP68S

ENVIRONMENTAL:

Operating Temp Range: -40°C to +85°C

Storage Temp Range: -40°C to +85°C

RFI: Withstand 100V/M, 14Hz to 1GHz

EMI: Withstand per MIL-STD-46 ID/SAE J1113-22 at 50Hz and 60Hz

MATERIALS:

Boot: Elastomer

Button: Thermoplastic, black

Case: Thermoplastic, black

Flange: Thermoplastic, black

Wires: 22 AWG

Mounting Hardware: Panel fastener assembly

2 & 4-WAY LINEAR HALL EFFECT TOGGLE

HTL2 PART NUMBER CODE

HTL2	-	X	X	X	X	1	X	XX	X	X	
Button Style		Case Style	Seal	Travel	Operating Force			Output 1 ①	Output 2 ②	Termination	Button Color
1. Castle 2. External Castle Boot 3. Short Double Stadium 4. Tall Concave Stadium 5. External Bat Handle Boot 6. External Smooth Boot 7. Long Concave Y Axis Button		1. 0.970" SQ.	1. Dusttight 2. Watertight	1. 25°	1. 16 oz			AA. 2.5 +/- 2.0VDC BB. 2.5 +/- 2.0VDC CC. 2.5 +/- 2.0VDC DD. 2.5 +/- 1.5VDC EE. 2.5 +/- 1.5VDC FF. 2.5 +/- 1.5VDC GG. 0.5 - 4.5VDC HH. 1.0 - 4.0VDC	NONE 2.5 +/- 2.0VDC 2.5 +/- 2.0VDC NONE 2.5 +/- 1.5VDC 2.5 +/- 1.5VDC 2.5 +/- 1.5VDC 0.5 - 4.5VDC 1.0 - 4.0VDC	1. Wire Leads 2. Pins	2. Black

① Outputs are from the center to the full travel position. Options "AA," "BB," "CC," "DD," "EE," and "FF" provide increased voltage in +Y; and decreasing voltage in -Y direction from one output per axis. Options "GG" and "HH" provide increasing voltages in all directions (+Y, -Y) from 2 outputs per axis.

② Options "BB" and "EE" provide redundant output 2 which duplicates output 1. Options "CC" and "FF" provide redundant output 2 which is inverse of output 1.

HTL4 PART NUMBER CODE

HTL4	-	X	X	X	X	X	XX	X	X	
Button Style		Case Style	Seal	Travel	Gating	Operating Force	Output 1 ①	Output 2 ②	Termination	Button Color
1. Castle 2. External Castle Boot 3. Short Double Stadium 4. Tall Concave Stadium 5. External Bat Handle Boot 6. External Smooth Boot 7. Long Concave Y Axis Button		1. 0.970" SQ.	1. Dusttight 2. Watertight	1. 25°	1. Ungated ③ 2. Gated ④ 3. Ungated Smooth Feel	1. 16 oz	AA. 2.5 +/- 2.0VDC BB. 2.5 +/- 2.0VDC CC. 2.5 +/- 2.0VDC DD. 2.5 +/- 1.5VDC EE. 2.5 +/- 1.5VDC FF. 2.5 +/- 1.5VDC GG. 0.5 - 4.5VDC HH. 1.0 - 4.0VDC	NONE 2.5 +/- 2.0VDC 2.5 +/- 2.0VDC NONE 2.5 +/- 1.5VDC 2.5 +/- 1.5VDC 2.5 +/- 1.5VDC 0.5 - 4.5VDC 1.0 - 4.0VDC	1. Wire Leads 22 AWG 18" 2. Pins	2. Black

① Outputs are from the center to the full travel position in each direction. Options "AA," "BB," "CC," "DD," "EE," and "FF" provide increased voltage in +X, +Y; and decreasing voltage in -X, -Y direction from one output per axis. Options "GG" and "HH" provide increasing voltages in all directions (+X, +Y, -X, -Y) from 2 outputs per axis.

② Options "BB" and "EE" provide redundant output 2 which duplicates output 1. Options "CC" and "FF" provide redundant output 2 which is inverse of output 1.

③ Ungated = Omnidirectional

④ Gated = Restricted movement in XY axis only

LINEAR HALL EFFECT TOGGLE

2 & 4-WAY LINEAR HALL EFFECT TOGGLE

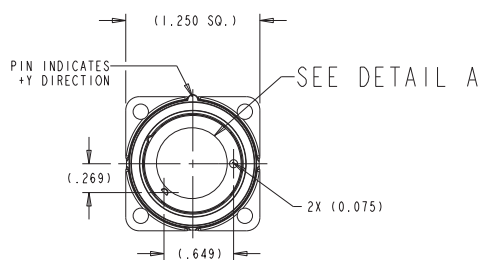
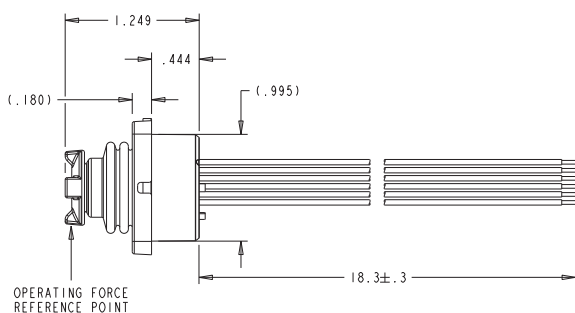
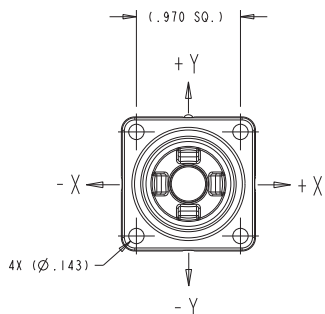
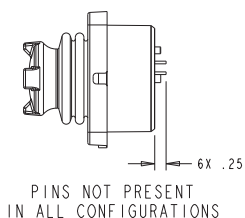

HTL2 FOOTPRINT

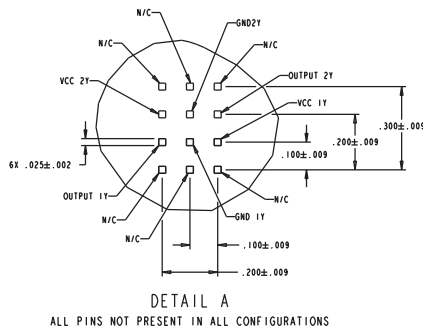
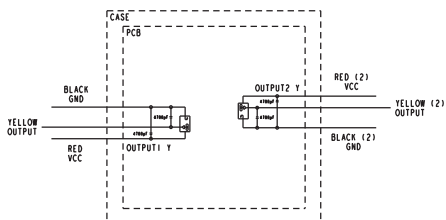

HTL4 FOOTPRINT

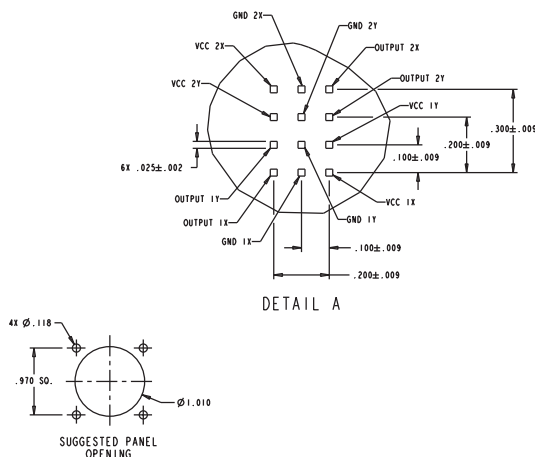
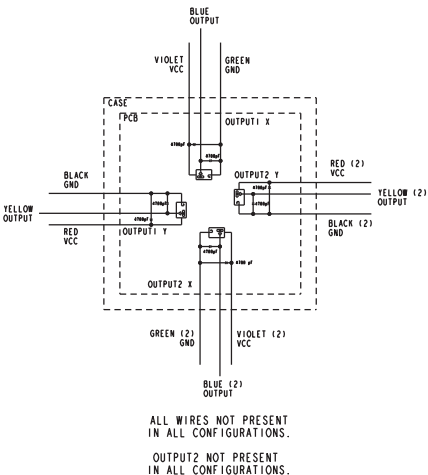

2 & 4-WAY LINEAR HALL EFFECT TOGGLE

HTL2 OUTPUTS

OPTION AA

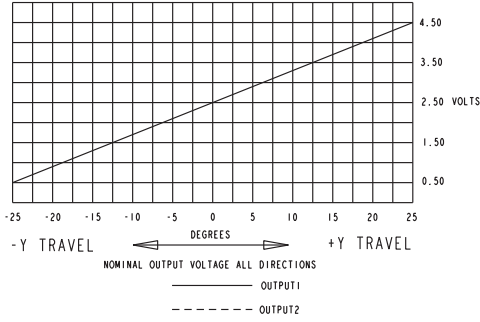

OPTION BB

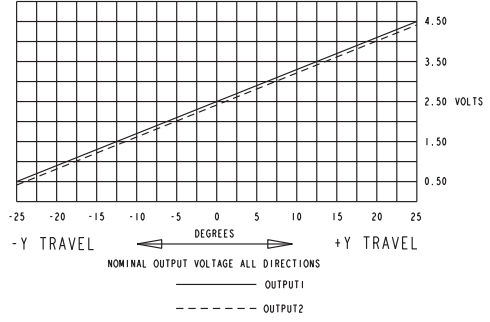

OPTION CC

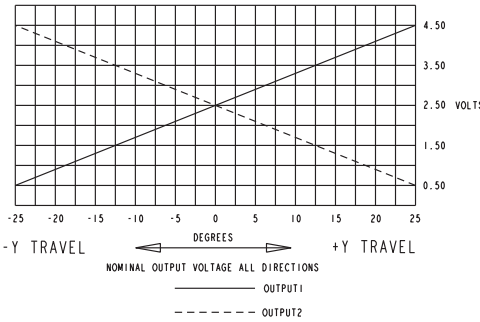

OPTION DD

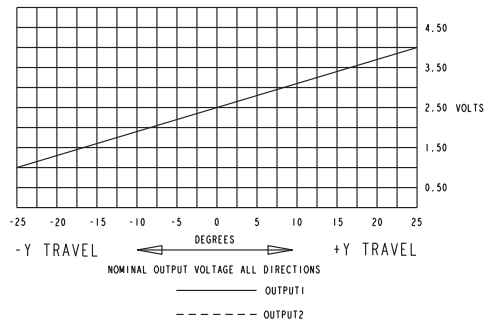

OPTION EE

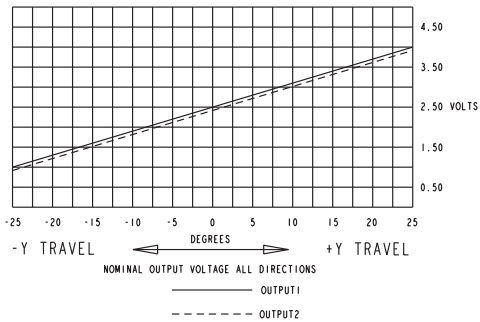

OPTION FF

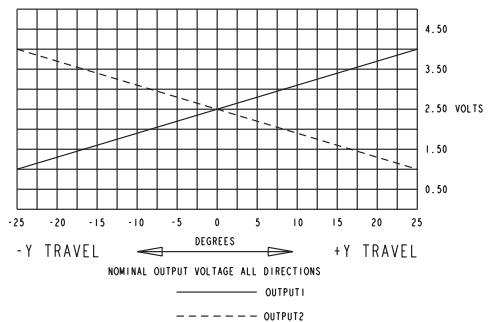

OPTION GG

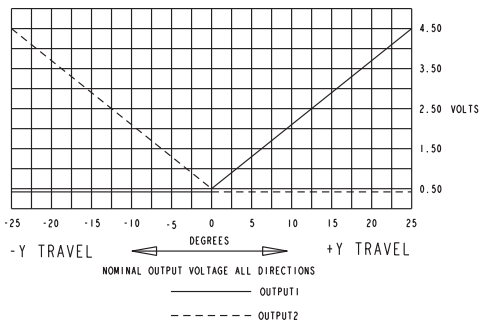

OPTION HH

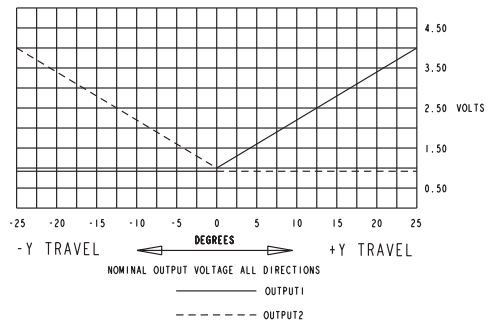

LINEAR HALL EFFECT TOGGLE

HTL
HALL EFFECT
TOGGLE

2 & 4-WAY LINEAR HALL EFFECT TOGGLE

HTL4 OUTPUTS

OPTION AA

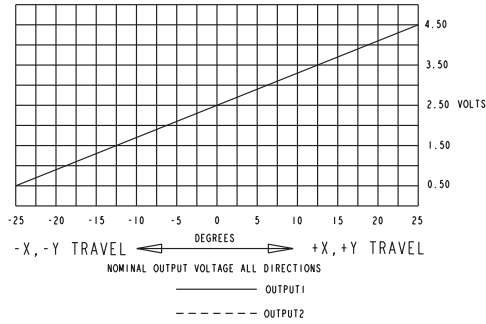

OPTION BB

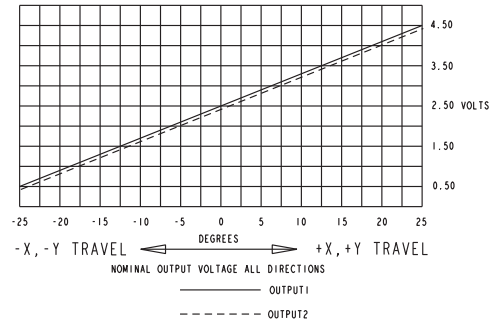

OPTION CC

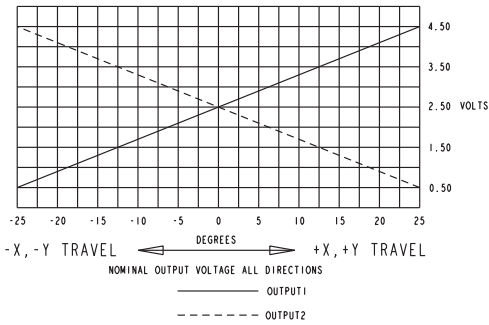

OPTION DD

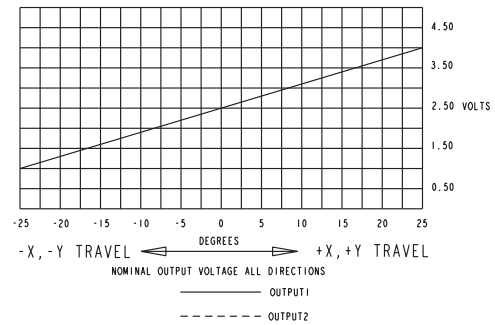

OPTION EE

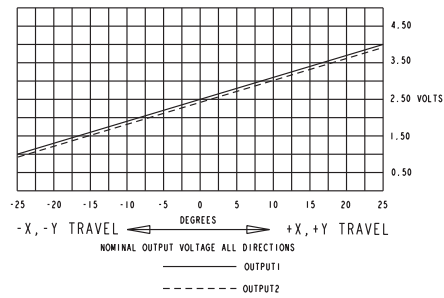

OPTION FF

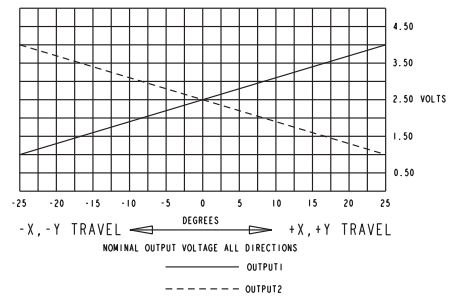

OPTION GG

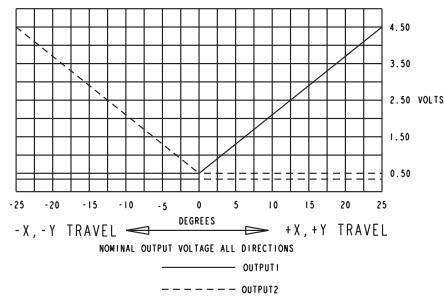

OPTION HH

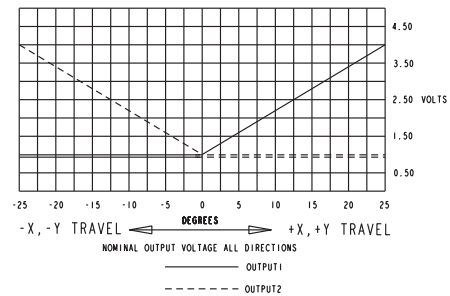

BUTTON STYLE

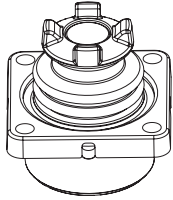

BUTTON STYLE 1
(CASTLE)

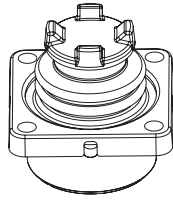

BUTTON STYLE 2
(EXTERNAL CASTLE BOOT)

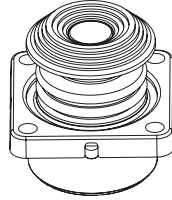

BUTTON STYLE 3
(SHORT DOUBLE STADIUM)

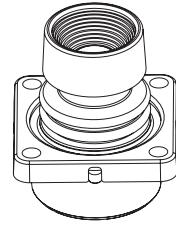

BUTTON STYLE 4
(TALL CONCAVE STADIUM)

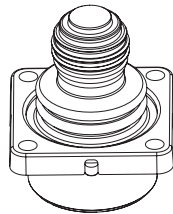
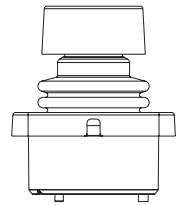
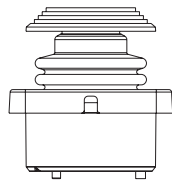
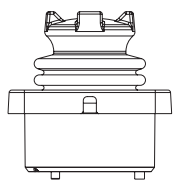
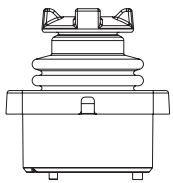

BUTTON STYLE 5
(EXTERNAL BAT
HANDLE BOOT)

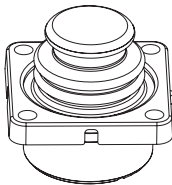

BUTTON STYLE 6
(EXTERNAL SMOOTH BOOT)

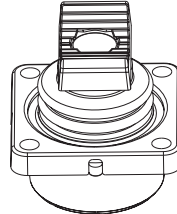

BUTTON STYLE 7
(LONG CONCAVE
Y AXIS BUTTON)

